

## **Veloce without Fascia (Open Front)**

Veloce No Fascia (open front, no crossbar) exhibitors who have ordered and paid for the booth package, will be provided with a **Veloce hard wall** system, consisting of poplar plywood (painted white) panels white wooden framework and a double-sided street sign with company name and booth number.

**NOTE: Booth configurations vary for this type of booth package.**  
**Show Management provides a specific schematic for the contracted booth size.**

Each Veloce No Fascia (Open Front) Booth Includes the Following:

- 8' high poplar wood panels (you are permitted to paint the walls yourself).
- Black booth carpeting will be installed without exception.
- 1 Chair upon request only. If you would like a chair, complete the wastebasket & chair form [HERE](#).
- 1 Wastebasket upon request only. If you would like a wastebasket, complete the wastebasket & chair form [HERE](#).
- 1 Double sided sign with name and booth number.
- All corner booths will have a 2' deep x 8' high side panel on the cross-aisle side.
- Lighting: Please see below for lighting package specifics. Power and labor for light fixtures is included.
- Vacuuming on the evening of Saturday, August 3 (night before show open).
- Drayage/Material handling consisting of crated and palletized shipments from the dock to the booth and the removal of freight at Show close. This does not include loose shipments, non-crated/non-palletized, small package shippers (Fed Ex, UPS, etc.) which will be subject to additional fees. Exhibitors are encouraged to ship crated or palletized to the Show.

This booth system is contiguous and difficult to alter. Keep this in mind when planning your display. Various wall treatments are permitted. Some acceptable examples are as follows: painting, wallpapering, draping, stapling, and nailing into the wall. All other equipment and services are the responsibility of the exhibitor. Online ordering (where available) and printable order forms are located within this kit.

If you are taking the packaged booth option, please be advised that wooden (painted white) framework will be in place overhead, around the sides, and in front of your booth(s) as a means of support. Where an exhibitor takes more than one space, support wall panels are provided as long as the request and an accompanying floor plan highlighting the position of the wall panels are received by the Operations Department on or before **July 5, 2024\***

\*NOTE - if the diameter of a nail or fastening device in the panel is larger than 6.3mm (0.25'), a refurbishing fee will apply. All panels should be left in as close to their original condition – remove nails, screws, adhesive wallpaper to avoid refurbishing fee. Exhibitors do not need to repaint the panels.

While we speak in feet the booth structure is built in meters – for exact measurements, please refer to the booth schematic provided by the show team. Please [click here](#) for the exact specifications sheet.

Freeman will service all on-site change requests on a time and material cost basis. Please be advised that exhibitors will be responsible for charges associated with the installation of any supports required for free standing and "angled" walls and doors. This booth system is contiguous and difficult to alter. Keep this in mind when planning your display. Various wall treatments are permitted. Some acceptable examples are as follows: painting, wallpapering, draping, stapling, and nailing into the wall.

### **Lighting per Booth Size**

<b>Booth Size</b>	<b>Veloce No Fascia # of Parcans</b>
5x10	1
5x20	1
5x30	2

## 5 x 10 INLINE – NO FASCIA

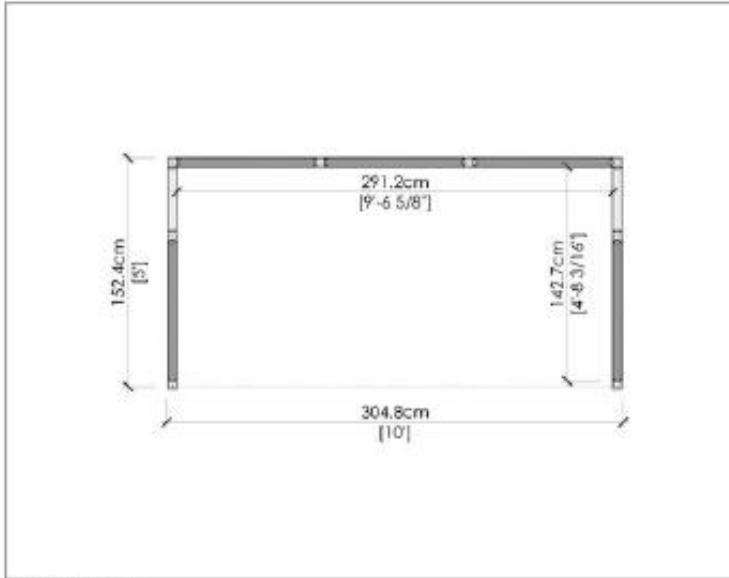

1 TOP VIEW

3 RENDERING

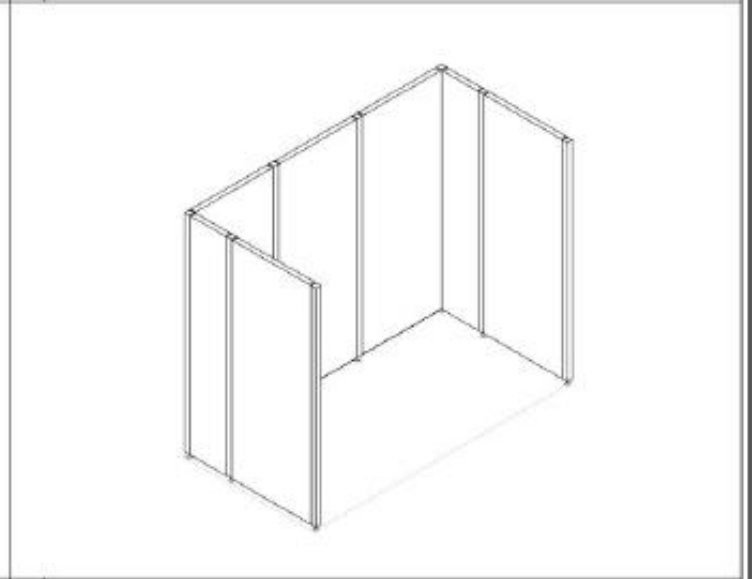
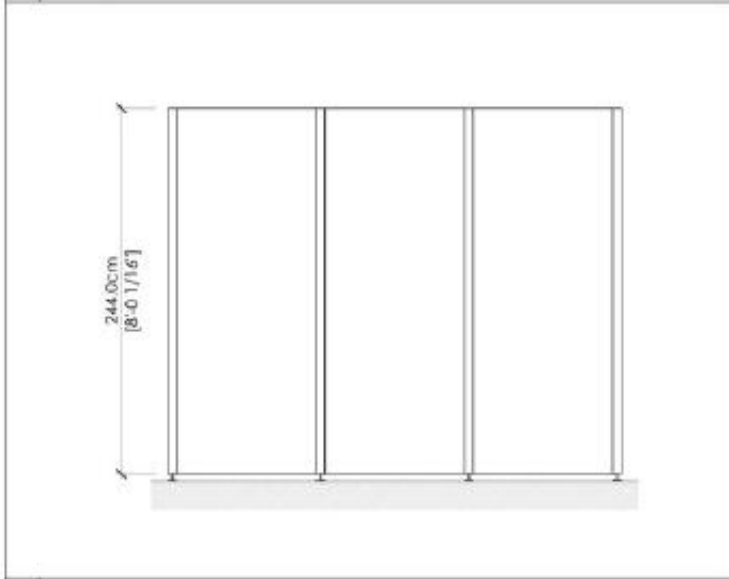

2 FRONT VIEW

4 3D VIEW

## 5 x 10 CORNER – NO FASCIA

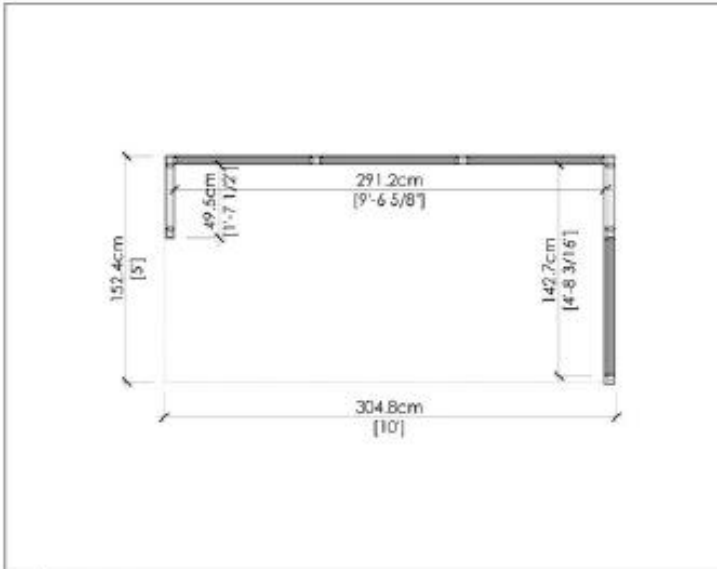

1 TOP VIEW

3 RENDERING

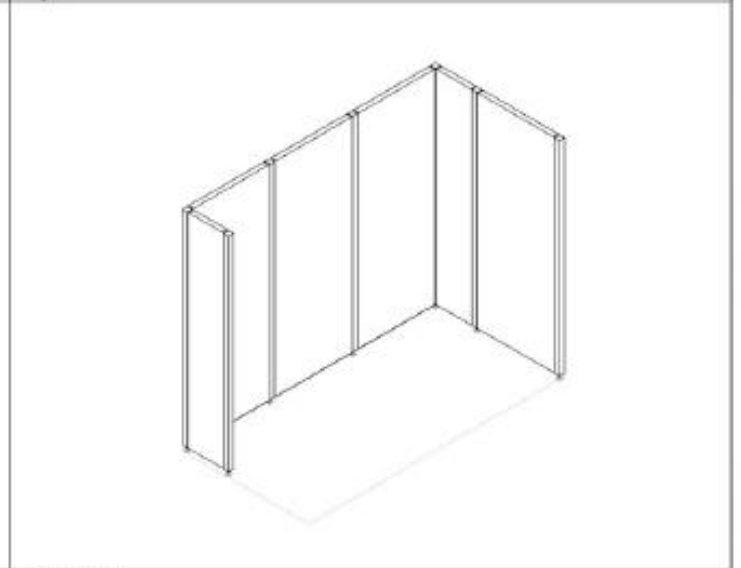
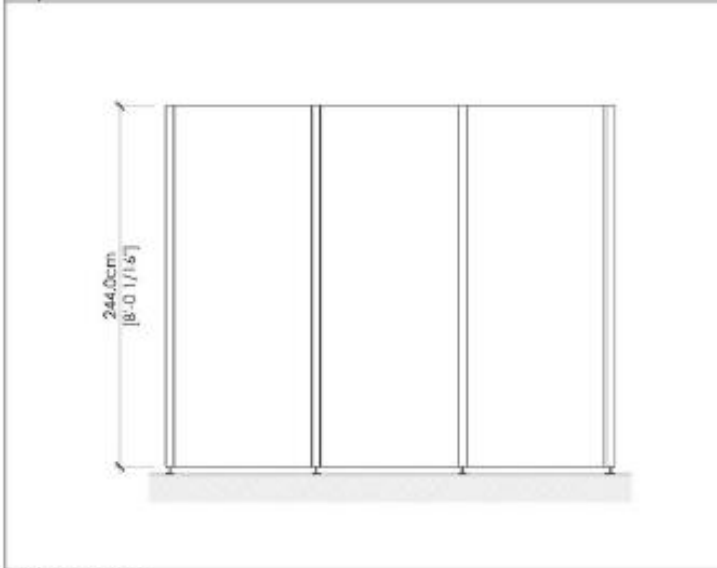

2 FRONT VIEW

4 3D VIEW

## 5 x 15 INLINE (CROSSBAR) – NO FASCIA

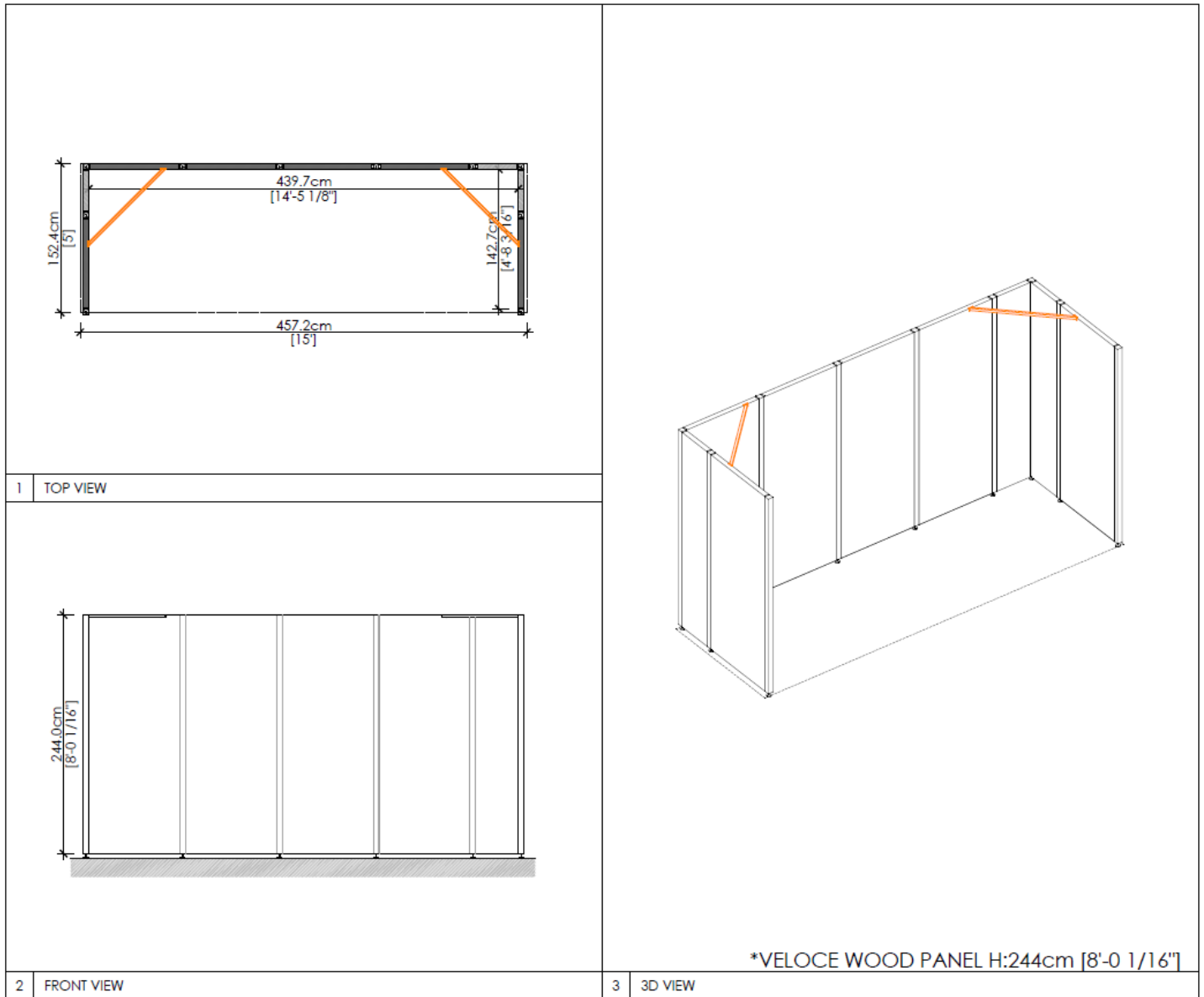

## 5 x 15 INLINE (BACK RETURNS) – NO FASCIA

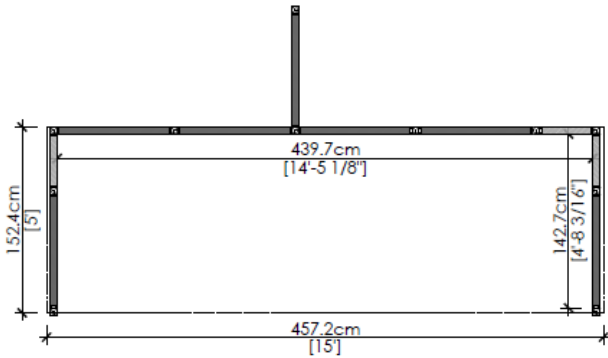

1 TOP VIEW

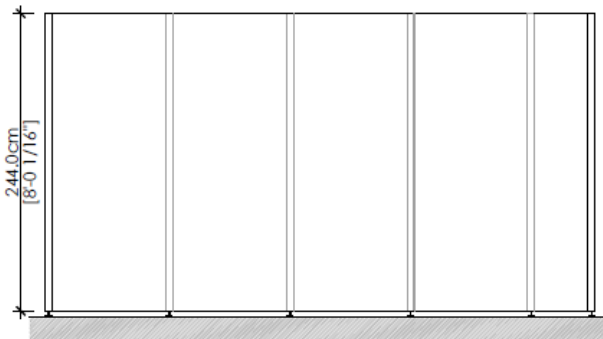

2 FRONT VIEW

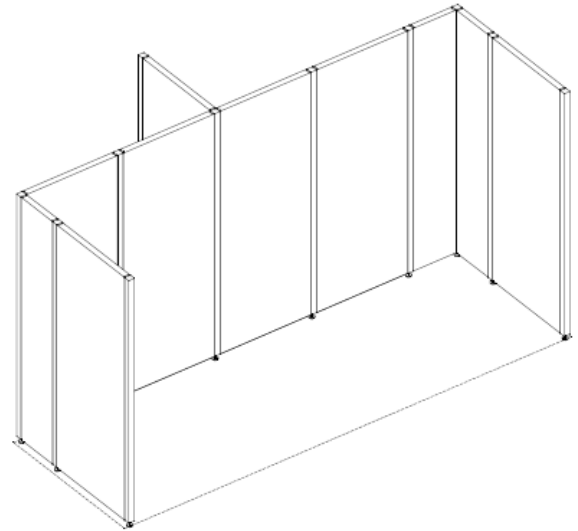

\*VELOCE WOOD PANEL H:244cm [8'-0 1/16"]

4 3D VIEW

## 5 x 15 CORNER (CROSSBAR) – NO FASCIA

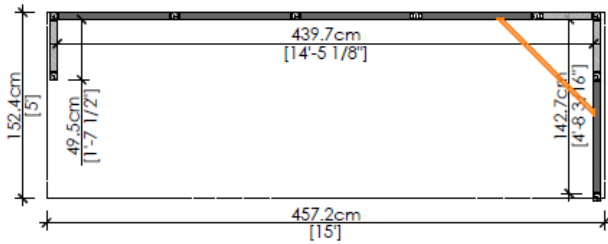

1 TOP VIEW

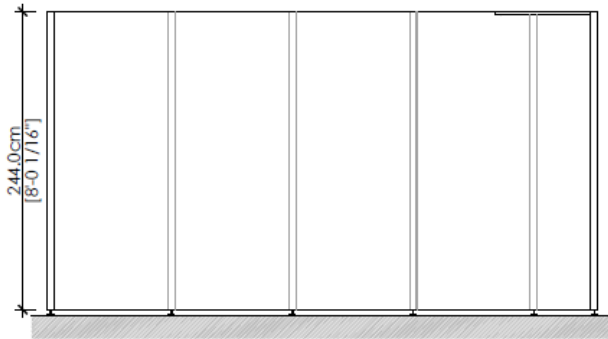

2 FRONT VIEW

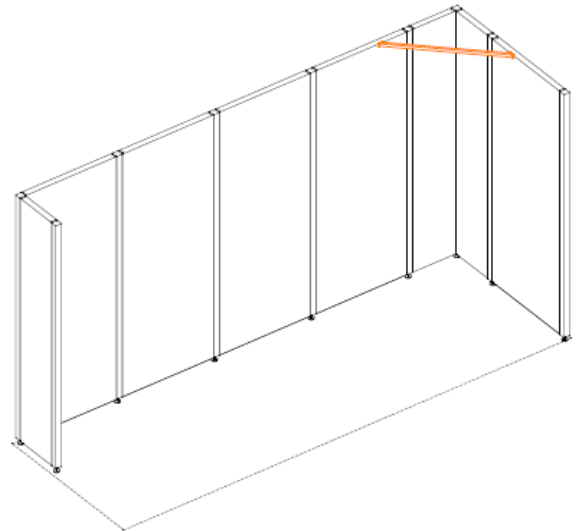

\*VELOCE WOOD PANEL H:244cm [8'-0 1/16"]

2 3D VIEW

## 5 x 15 CORNER (BACK RETURNS) – NO FASCIA

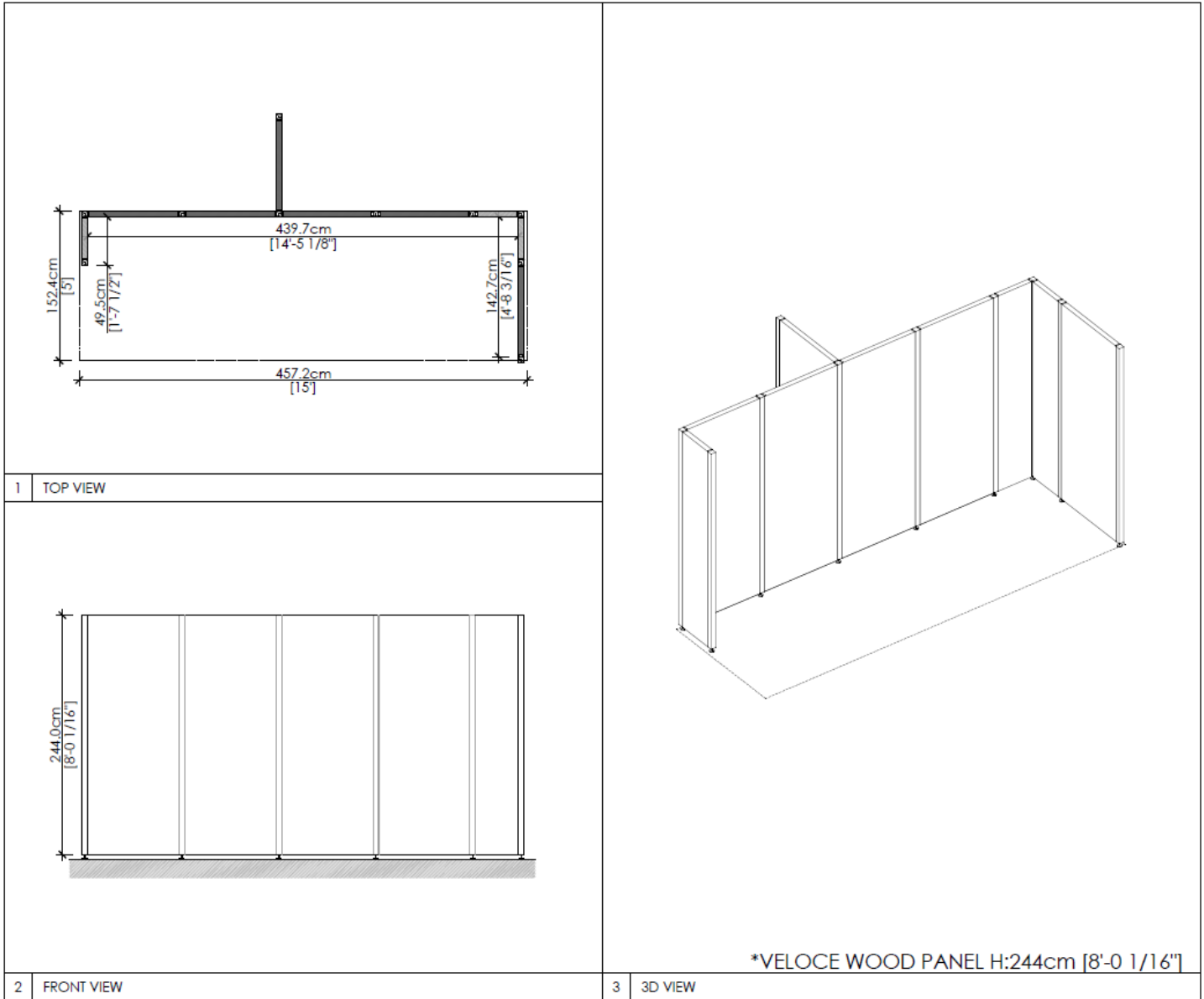

## 10 x 10 INLINE – NO FASCIA

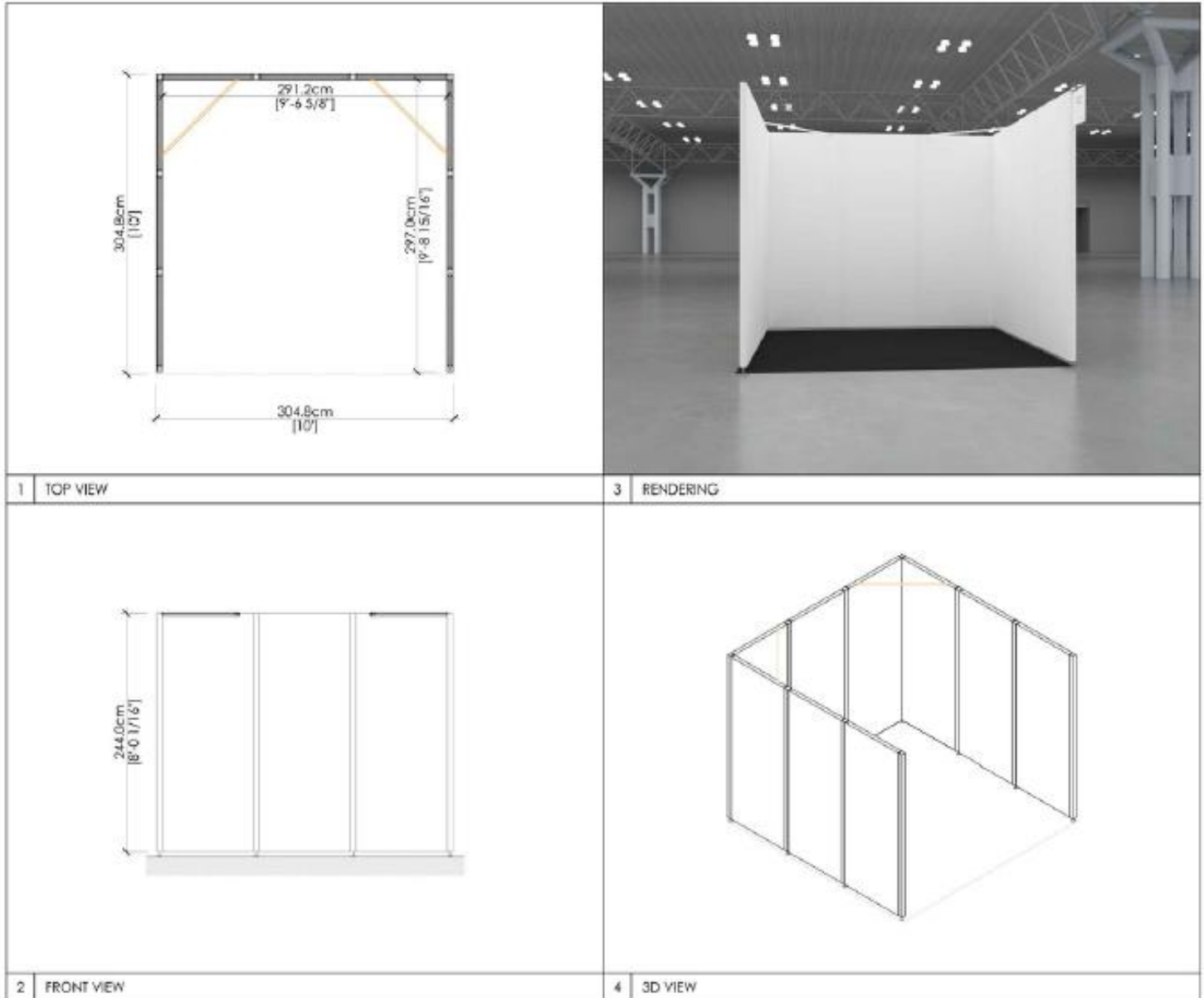



# 10 x 10 CORNER – NO FASCIA

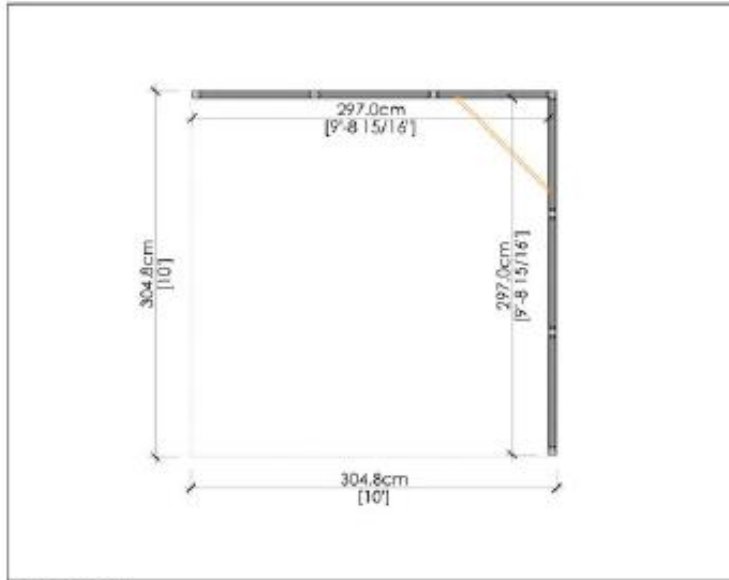

1 TOP VIEW

3 RENDERING

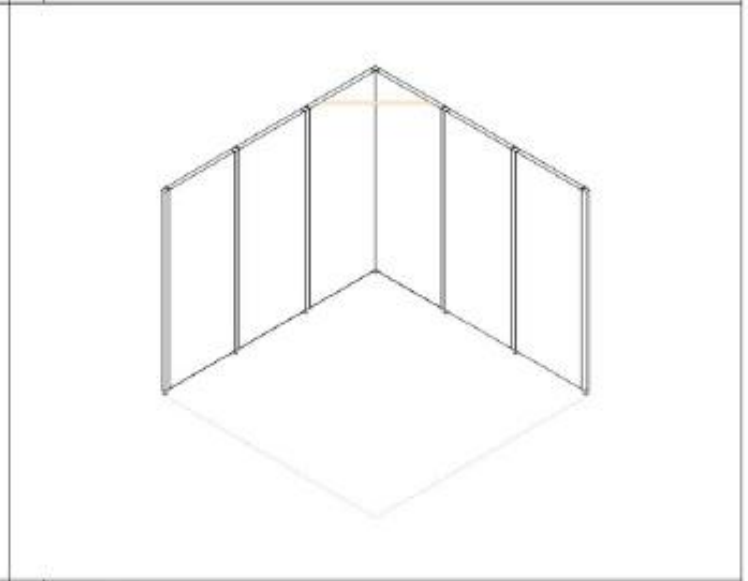
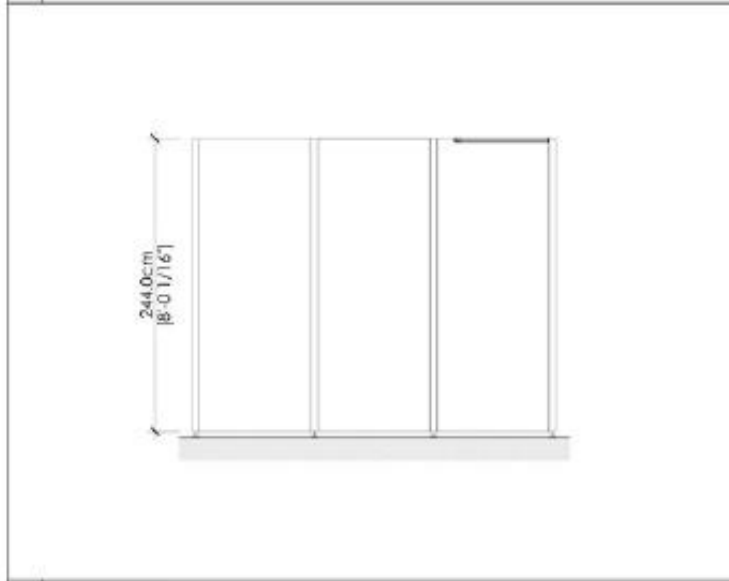

2 FRONT VIEW

4 3D VIEW

## 10 x 15 INLINE – NO FASCIA

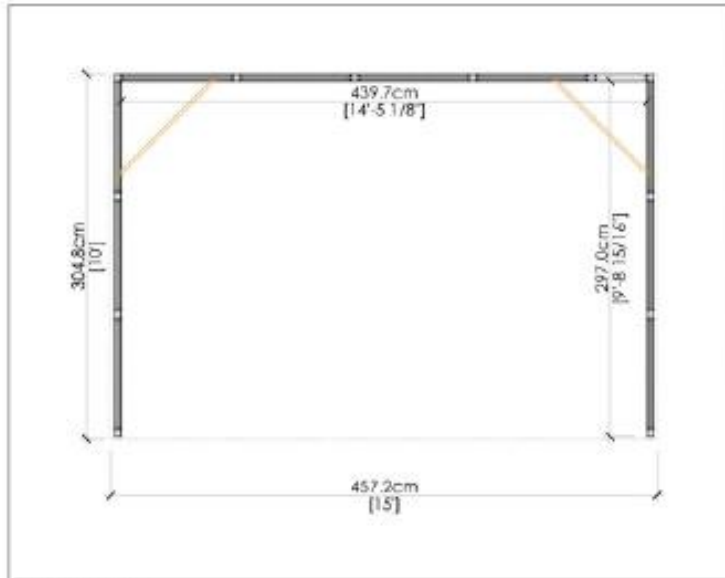

1 TOP VIEW



3 RENDERING

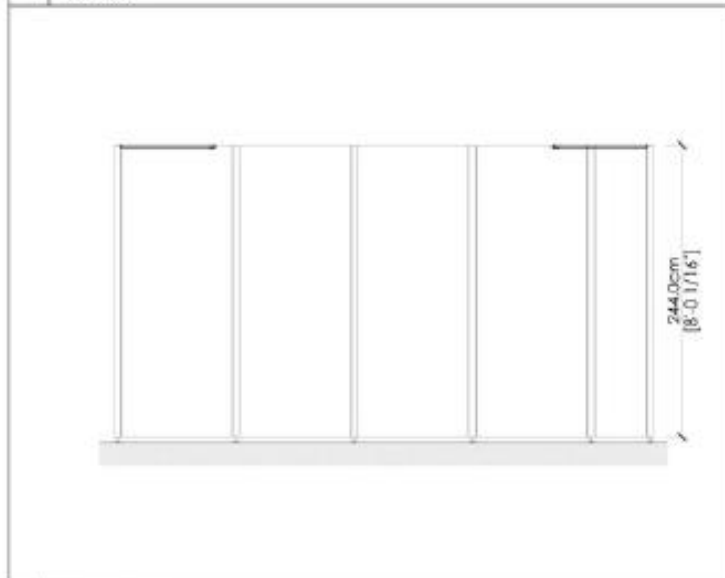

2 FRONT VIEW

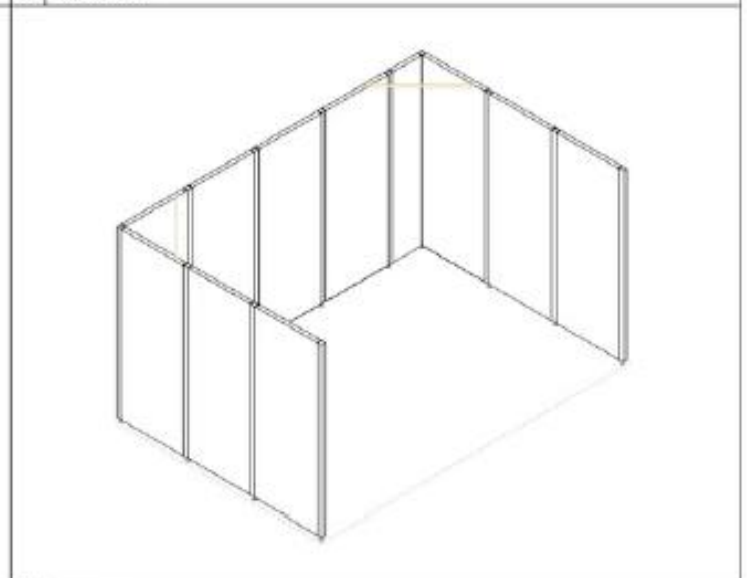

4 3D VIEW

## 10 x 15 CORNER – NO FASCIA

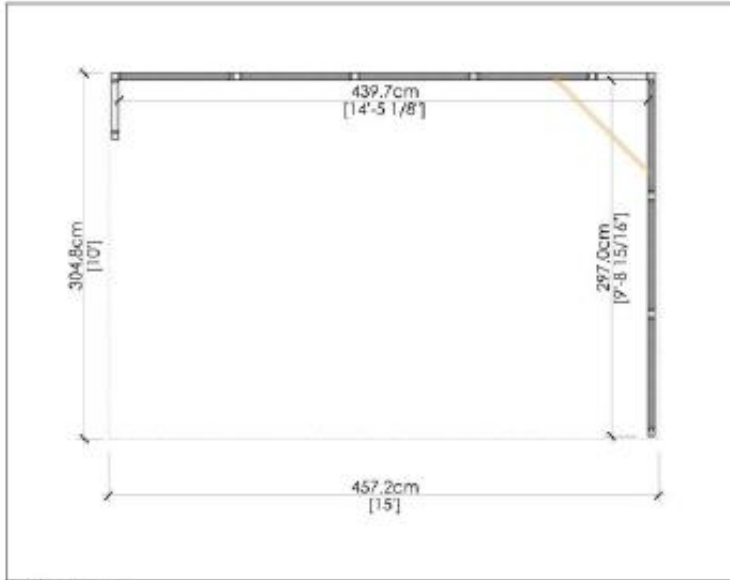

1 TOP VIEW

3 RENDERING

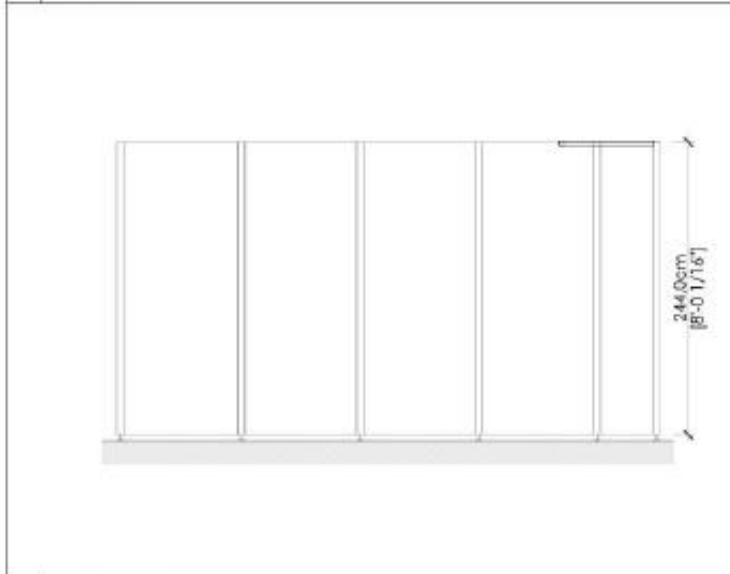

2 FRONT VIEW

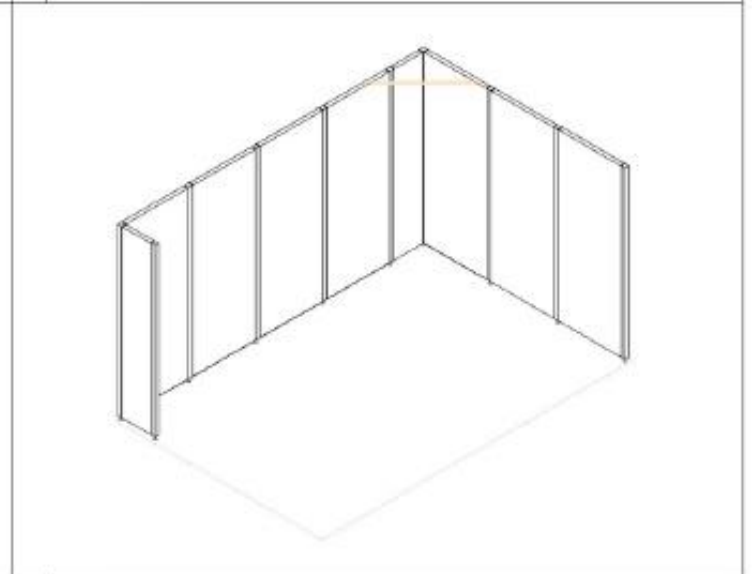

4 3D VIEW

## 10 x 20 INLINE – NO FASCIA

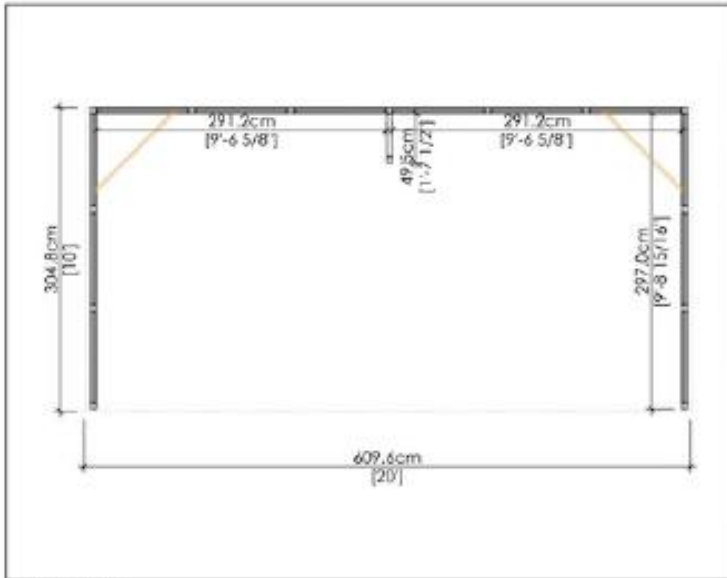

1 TOP VIEW

3 RENDERING

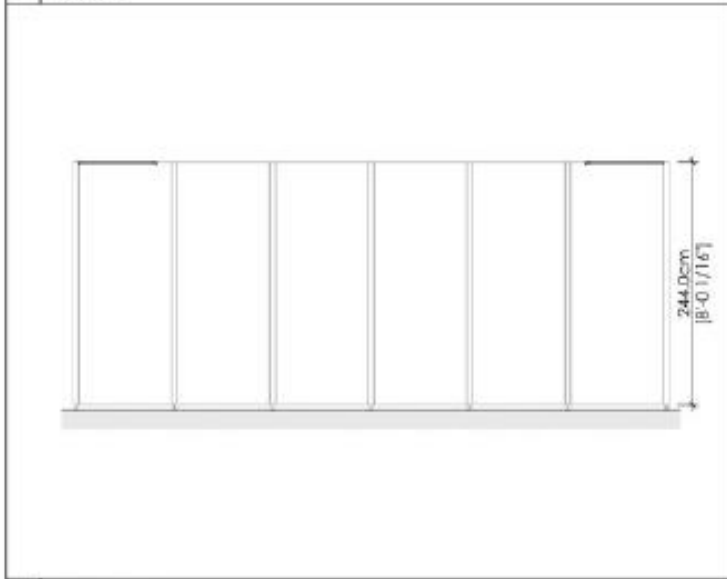

2 FRONT VIEW

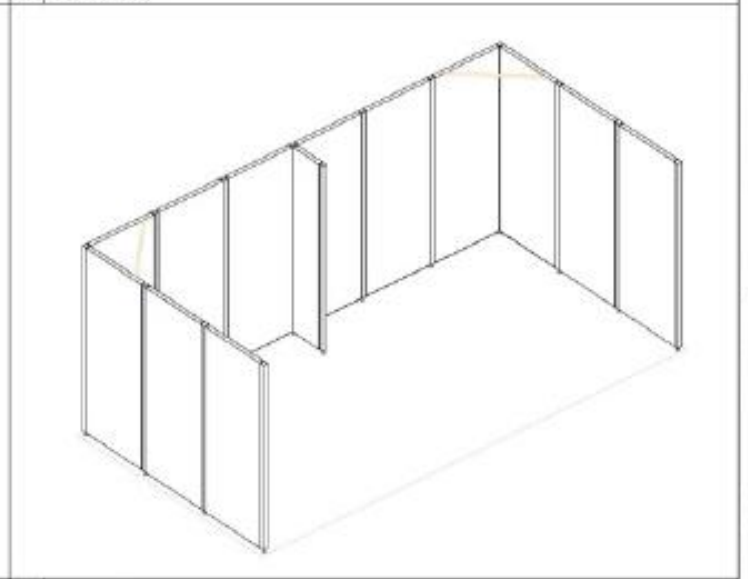

4 3D VIEW

## 10 x 20 CORNER – NO FASCIA

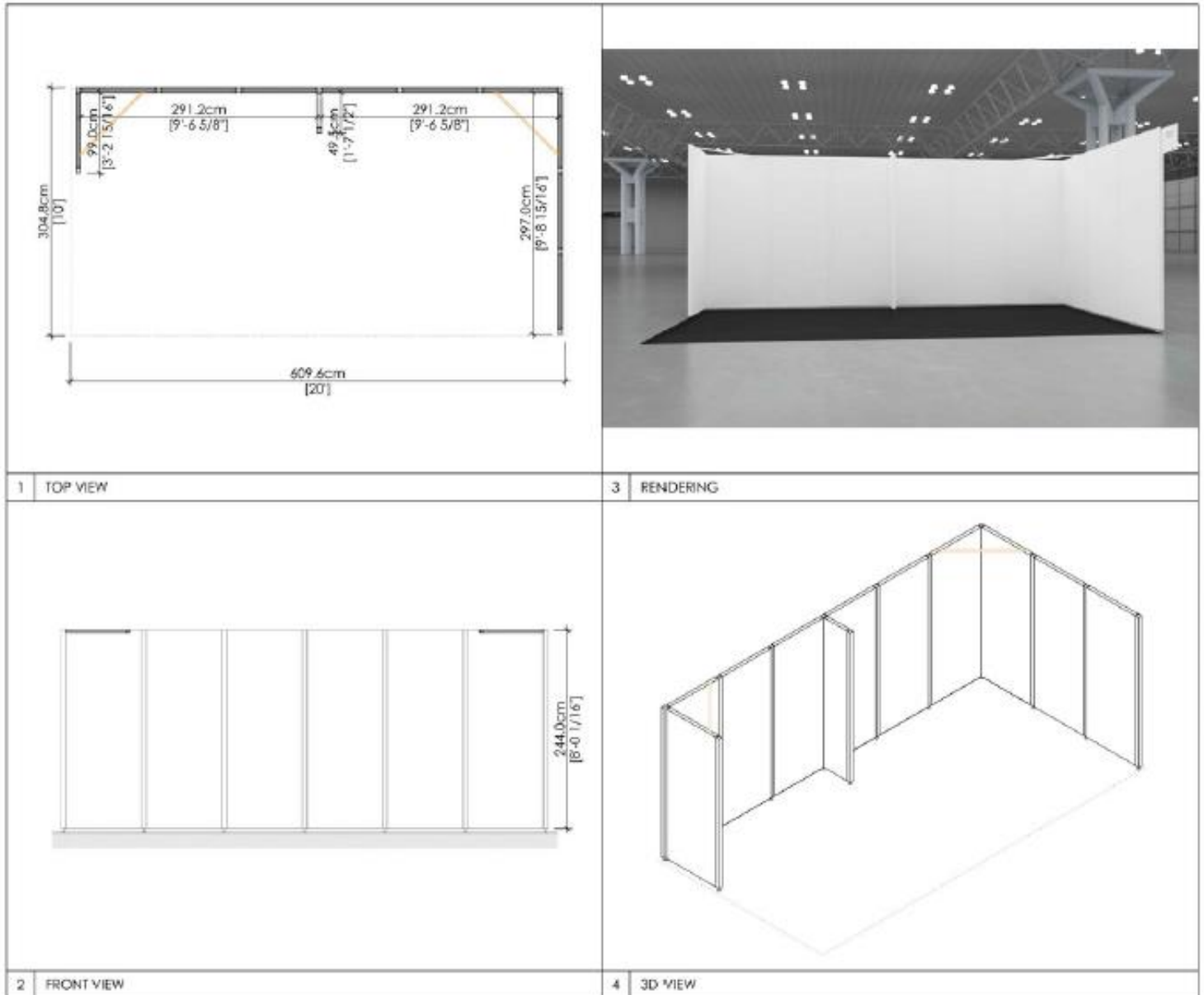

## 15 x 20 INLINE – NO FASCIA

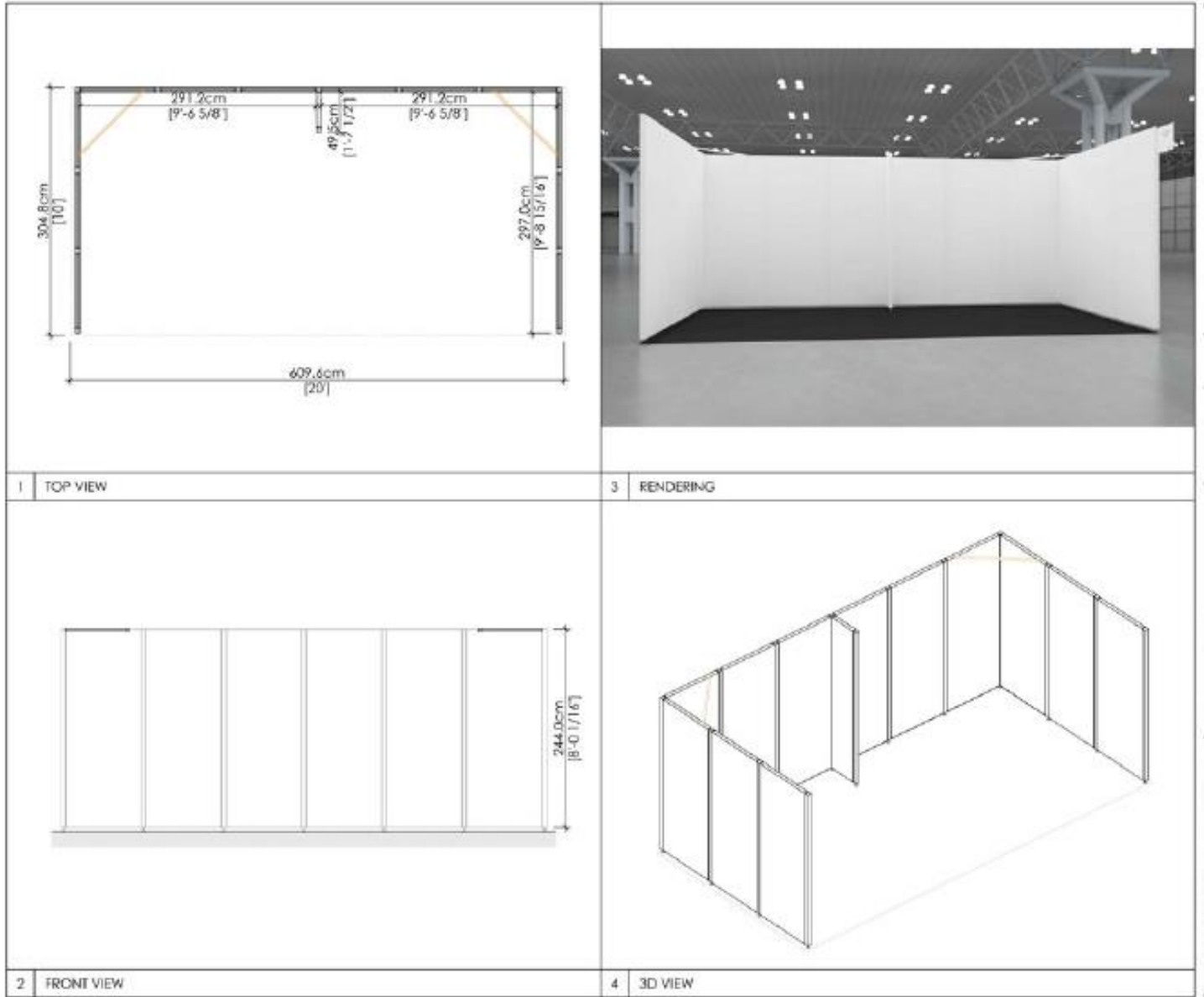

## 15 x 20 CORNER – NO FASCIA

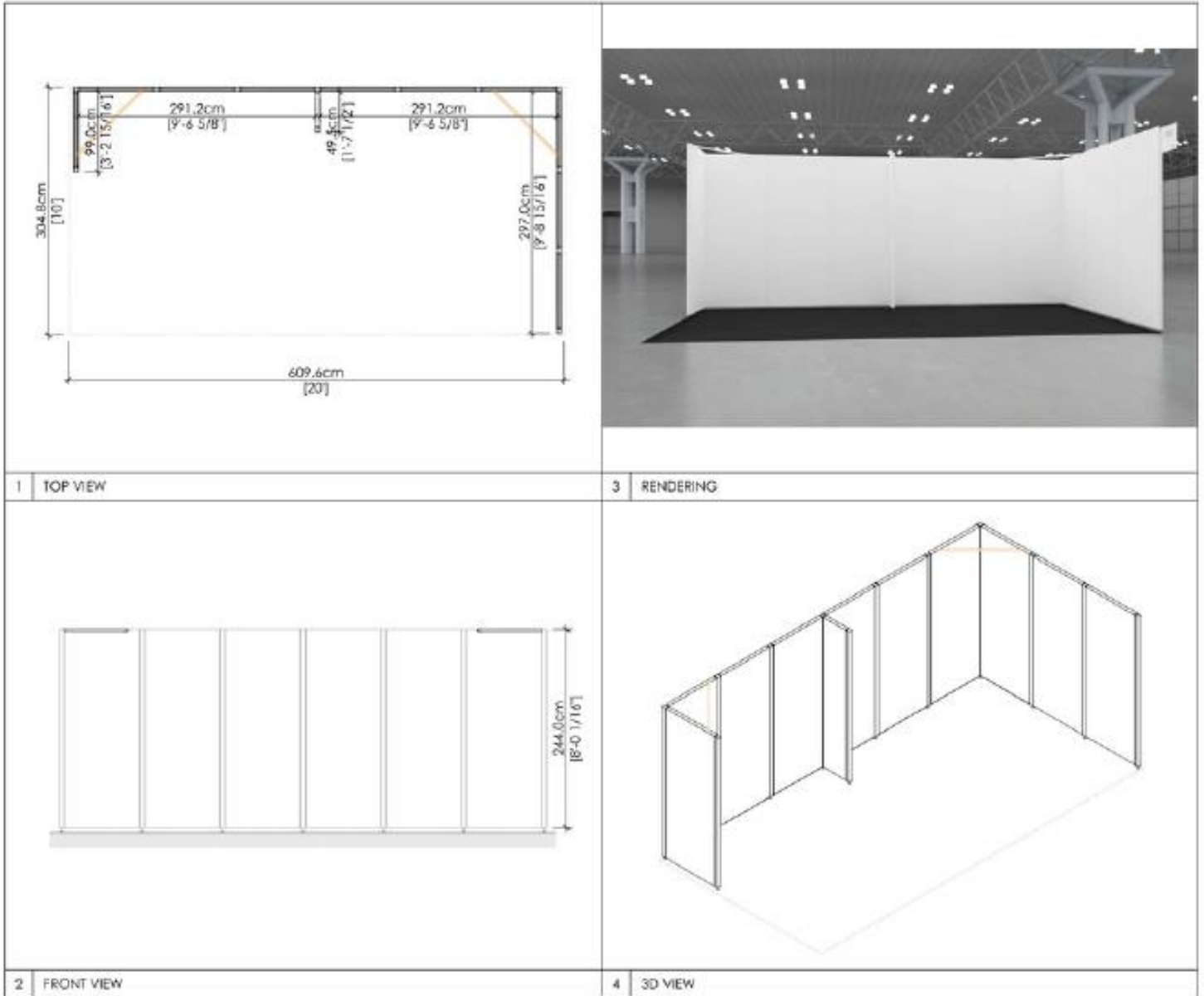

### 20 x 25 PENINSULA – NO FASCIA

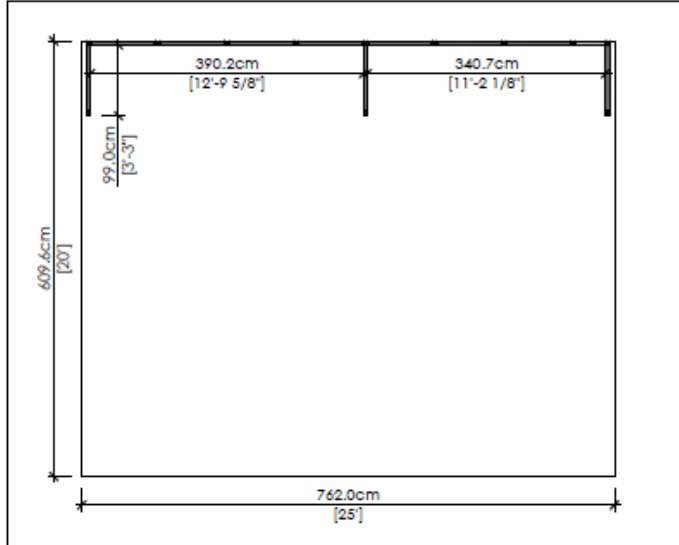

1 TOP VIEW

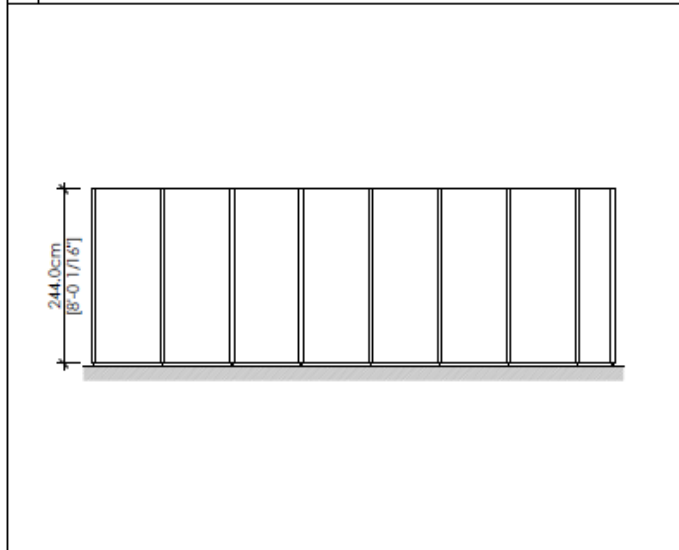

2 FRONT VIEW

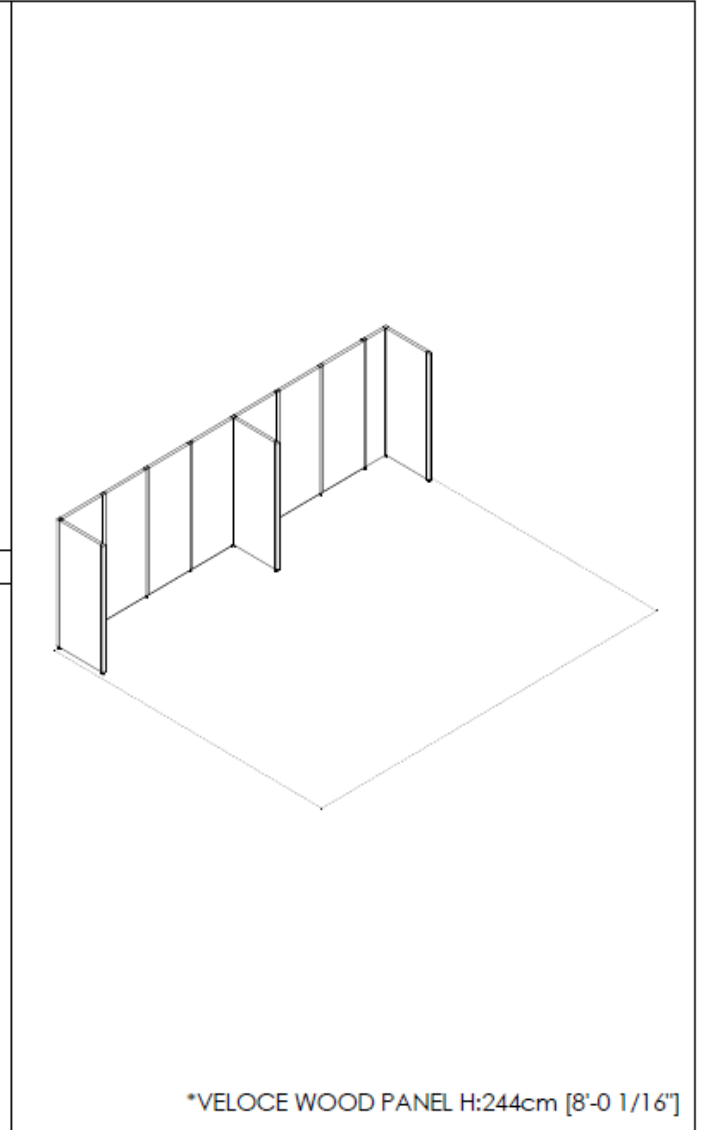

4 3D VIEW